

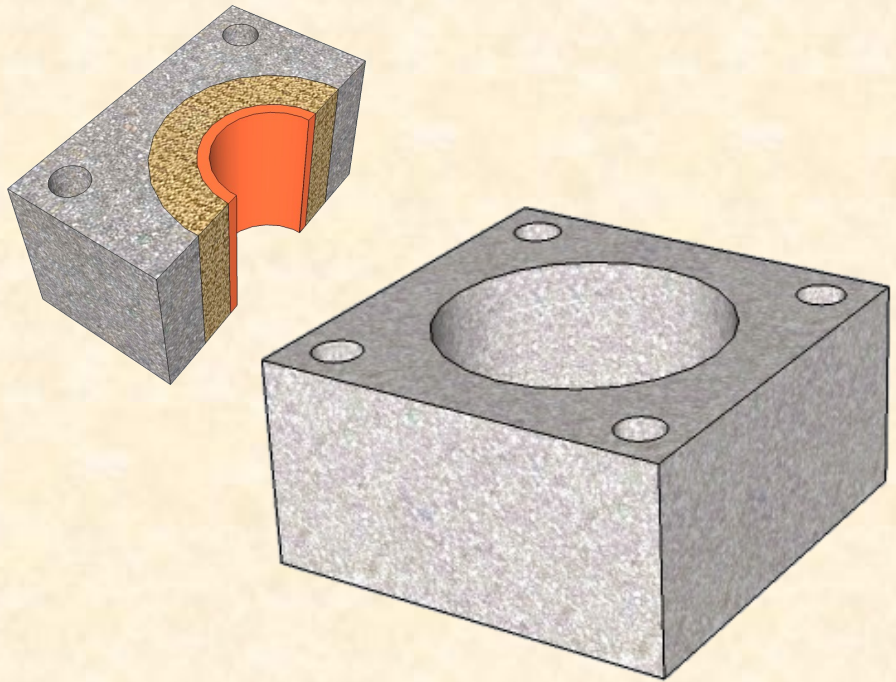

# Dineen Sales Ltd.

## Modular Chimney Blocks



Dineen Sales Ltd.

**Dineen Modular Chimney Blocks** combine traditional ceramic flue liners with a lightweight Modular Block, manufactured from expanded clay aggregate and cement. Dineen Vermiculite is used as insulation between the Dineen flue and Dineen block, making an integrated unit.



The blocks may be joined together to facilitate the erection of a chimney on an outside elevation attached to a stove, or within the property connected to a traditional fire or modern stove.

**Dineen Sales Ltd.**

Wolfhill,  
Athy,  
Co. Kildare

Phone: (059) 8635557  
Fax: (059) 8635655  
E-mail: [info@dineensales.com](mailto:info@dineensales.com)

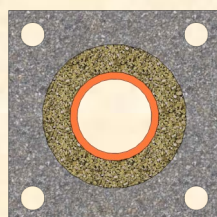

Dimensions: 440x440x220mm  
300mm diameter hollow  
50mm holes for optional steel tie rods  
Weight per block 23kg

